

DURABILITY INCREASE OF FIELD PIPELINES SUBJECTED TO GROOVING CORROSION

Sultanmagomedov S.M.

The Ufa state petroleum technical university

The analysis of fault rates of field pipelines shows, that to one of the principal causes causing refusal is groove fretting on the bottom forming internal surface of a wall of a pipe.

It is caused complex is intense - deformed by a condition of the pipeline, simultaneous influence on metal of water contained in petroleum, gas and using up influence of abrasive particles [1]. As a rule, in these conditions pipelines are laid without external isolation since speed of the groove fretting attain 2 ... 3 mm / year, and term of operation is reduced sometimes till 3 years.

The offered method of increase of term of operation of the pipeline subject to groove fretting, consists that on the struck site turn the pipeline be relative its longitudinal axis on some angle φ (fig. 1). In the result, the available groove moves from a zone of active destruction in a zone protected from its formation. Residual thickness of a wall of the pipeline in the groove before performance of turn should be not less safe operation of the pipeline admitted from a condition.

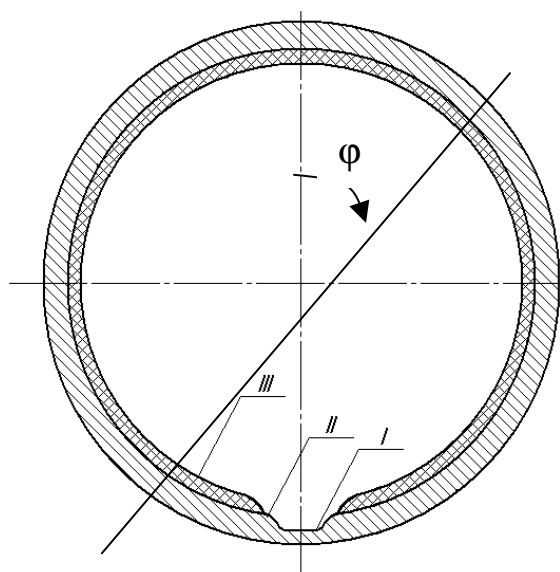
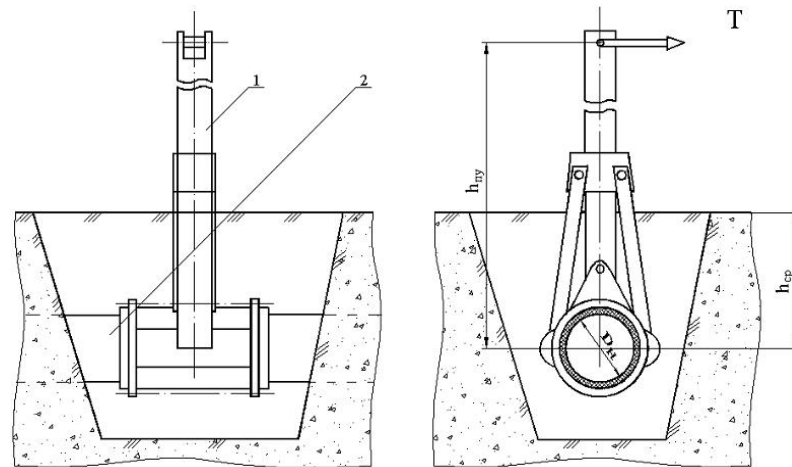

Fig. 1. The circuit of turn of the pipeline with groove fretting:
/ - a groove; // - the bared site; /// - technological crust

Turn is carried out by transfer of twisting moment from mounting devices to the pipeline due to forces of friction between them. For this purpose mounting device is fixed on the given section of a pipe (fig. 2) and nipping it so that at its turn with the help of the force mechanism the section of a pipe on which it is established turned also. Thus the site of the pipeline of the certain length will turn. This length is accepted for distance up to the following section l_m , where it is necessary to establish mounting device (fig. 3). After turn of the second section the first mounting device is removed and device on the third section and carries out its turn. So, consistently or simultaneously, depending on characteristics and lengths of the struck site of the pipeline, carry out its turn. Now, the available groove on all the struck site is removed on a lateral surface and protected from the further active groove fretting.

The offered way of increase of durability allows increasing term of operation of the pipeline in 2 ... 3 times and more.



**Fig. 2. The circuit of transfer of twisting moment on the underground pipeline:
1 - mounting device; 2 - the pipeline**

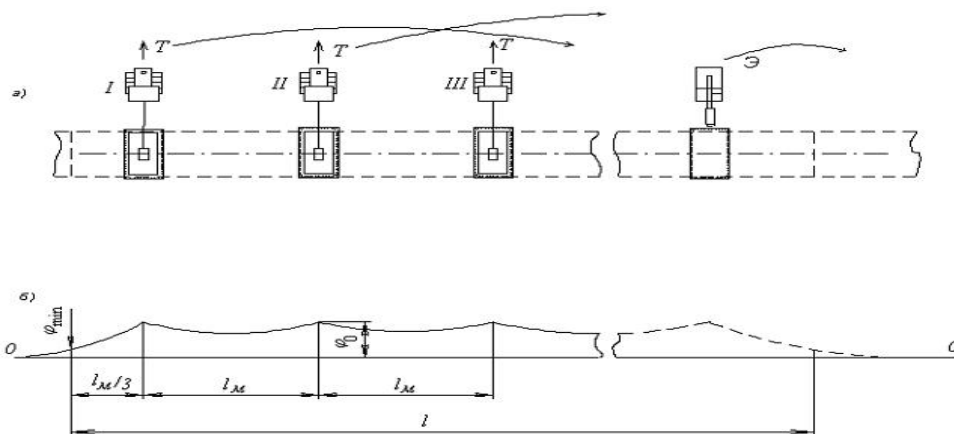

**Fig. 3. The technological circuit of turn of the pipeline without cutting:
a - an arrangement of turning mechanisms; b - graph a angle of turn**

Now, the faculty of strength of materials USPTU together with Open Society "Роснефть-Дagneфть" and "Башнефть" will investigate preventive repair of pipelines by a method of turn.

At active participation Open Society "Аксаковнефть" of 6676 m (ГКНС - КНС-3) were investigated by some questions which have arisen during performance of turn of the field pipeline 325x10, in the extent, namely:

- Research of a cross bends of the pipeline at preventive repair and a way of its exception;
- Influence of curvature of an axis of the pipeline on its torsion;
- Loss of longitudinal and cross stability of the pipeline at its turn mounting device;
- Definition of residual durability of the pipeline subject groove fretting etc.

At the same time, practical application of preventive repair of pipelines puts new questions:

- Designing and application mounting devices, controlled as the hinged equipment;
- Development of the actions, allowing turning the pipeline with external isolation;
- The account of initial abnormality of geometry of a pipe at its turn etc.

Simultaneous turn of two and more sections of the pipeline causes imposing deformations and intensity on adjacent sites. Therefore, at performance of preventive repair of the pipeline it is necessary to define optimum technological parameters.

Let's consider the pipeline on which operate two concentrated twisting moments located on distance l and $2l$ from beginning of coordinates (fig. 4).

The twisting moments arising in cross sections of the pipeline are equal: for $0 \leq x_1 \leq l$:

$$M_K = M_O + mx_1 = \begin{cases} x_1 = 0, M_K = 0; \\ x_1 = l, M_K = ml, \end{cases} \quad (1)$$

for $l \leq x_2 \leq 2l$:

$$M_K = -2ml + mx_2 + m(x_2 - l) = \begin{cases} x_2 = l, M_K = -ml; \\ x_2 = 2l, M_K = ml. \end{cases} \quad (2)$$

Knowing the appropriate ordinates in characteristic sections, we build graph (fig. 4). Angles of turns of any sections, accordingly for both sites are equal:

$$\varphi_{x_1} = \varphi_O + \int_0^l \frac{mx}{GI_p} dx = \frac{mx^2}{2GI_p}, \quad (3)$$

at $x_1=0, \varphi_{x_1} = 0$;

at $x_1=l, \varphi_{x_1} = \frac{ml^2}{2GI_p}$;

$$\varphi_{x_2} = \varphi_O + \int_l^{2l} \frac{M_K dx}{GI_p} = \frac{ml^2}{2GI_p} + \int_l^{2l} \frac{-2ml + mx + m(x-l)}{GI_p} dx = \frac{ml^2}{2GI_p} + \left(\frac{mx^2}{GI_p} - \frac{3mlx}{GI_p} \right) \Big|_l^{2l}, \quad (4)$$

I.e. at $x=l$ and $x=2l$ angles of turns of these sections are equal each other and make

$$\varphi = \frac{ml^2}{2GI_p}.$$

On a site of imposing of action of two mounting devices transmitting twisting moments to sections of the pipeline it is necessary to construct the graph of angles of a twisting. On the graph it is possible to determine the least value of a angle of turn between mounting devices, and also the relation between the least and the greatest angles of turn on length.

For the any section located on a site between mounting devices, the angle of turn is determined, using a principle of superposition, under the following formula:

$$\varphi_x = \frac{mx^2}{2GI_p} - \frac{2ml(x-l)}{GI_p} + \frac{m(x-l)^2}{2GI_p}, \quad (5)$$

where GI_p - rigidity of cross section of the pipeline at torsion;

$m = \tau_{GP} \frac{\pi D^2 H}{2}$ - the moment of strength of the ground, distributed on unit of length;

τ_{TP} – shearing stresses on contact a pipe - ground, dependent on characteristics of a ground.

Let's enter a designation $\beta = \frac{m}{2GI_p}$ and we shall receive the equation of a parabola

which looks like: $\varphi_x = \beta x^2 + \beta(x-l)^2 - 4\beta l(x-l)$.

Analyzing last equation, we shall receive for characteristic sections:

at $x=l$, $\varphi_x = \beta l^2$; at $x=1,5l$, $\varphi_x = \beta l^2 / 2$; at $x= 2l$, $\varphi_x = \beta l^2$.

For definition of the least angle of turn, we shall equate to zero the equation of twisting moments on this site, i.e.

$$M_K = -2ml + mx + m(x-l) = 0.$$

The received value $x=1,5l$ gives the minimal angle of turn (fig. 4)

$$\varphi_{MIN} = \frac{ml^2}{4GI_p}. \quad (6)$$

Knowing the greatest values of a angle of turn from l up to $2l$, equal $\varphi_{MAX} = \frac{ml^2}{2GI_p}$,

appropriate to section of the pipeline where it is established mounting device, we shall determine distance between turning mechanisms l_m , at which the least angle of turn provides protection from groove fretting.

Since on a considered site there is an imposing angles of turn from action of two concentrated moments, using a principle of superposition, shall find such value x , at which the condition is satisfied:

$$2\varphi_x = \varphi_{MAX},$$

or $2\beta x^2 = \beta l^2$, whence

$$x = \frac{l}{\sqrt{2}} \approx 0,7l. \quad (7)$$

Hence, at work of one turning mechanism, on distance $0,3l$ from it we have a angle of turn two times less than in section where it is established itself mounting the device. Then, at simultaneous turn of two sections of the pipeline, distance between them (i.e. the distance between turning mechanisms l_m) should be less than or equal $0,6l$. Where l - distance on which on both sides from mounting devices the angle of turn is distributed [2]. For simplification of conclusions, the assumption here is accepted, that at $x = 0$ the angle of turn and twisting moment are equal to zero.

It is necessary to note, that the greatest angle of turn will increase on some size if distance l_m to accept equal $0,6l$.

Then,

$$\varphi'_{max} = \varphi_0 = \beta l^2 + \beta x^2, \quad (8)$$

where $x = 0,4l$.

Having substituted value x , we shall receive an initial angle of turn of section in which it is established mounting the device (fig. 5):

$$\varphi_l = \varphi_{2l} = 1.16\beta l^2. \quad (9)$$

The distance, on which (to the left of the first is of interest the turning mechanism) minimally necessary angle of turn is provided.

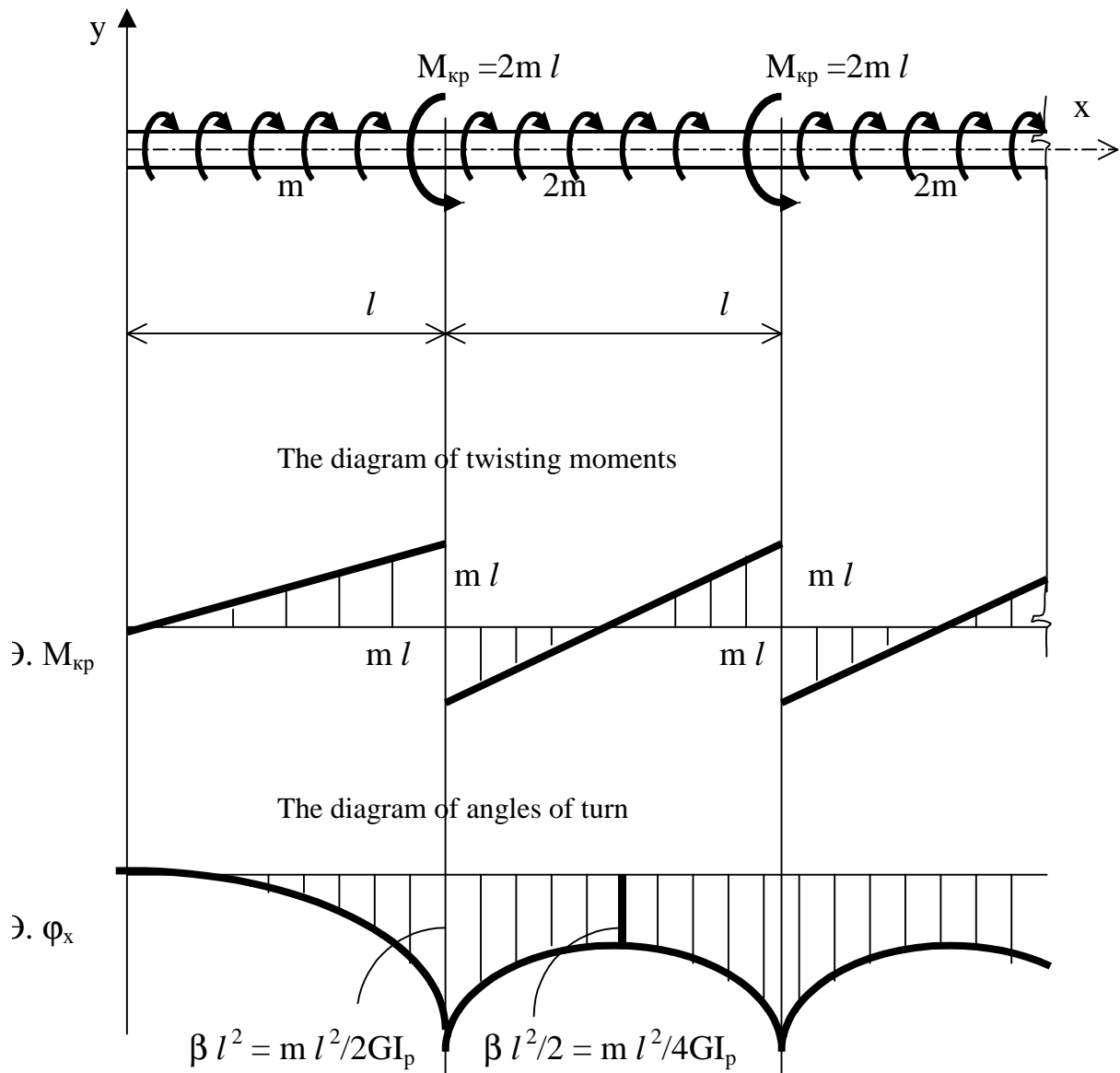

Fig.4. The scheme of turn of the underground pipeline

Let's consider a site of the pipeline from 0 up l (fig. 5). From told follows above, that at $0 \leq x \leq 0,6l$:

$$\varphi_x = \beta x^2,$$

and on a site $0,6l \leq x \leq l$:

$$\varphi_x = \beta x^2 + \beta(x - 0,6l)^2.$$

Supposing $\varphi_x = \varphi_{\min}$, we shall receive

$$\beta l^2 = \beta x^2 + \beta(x - 0,6l)^2. \quad (10)$$

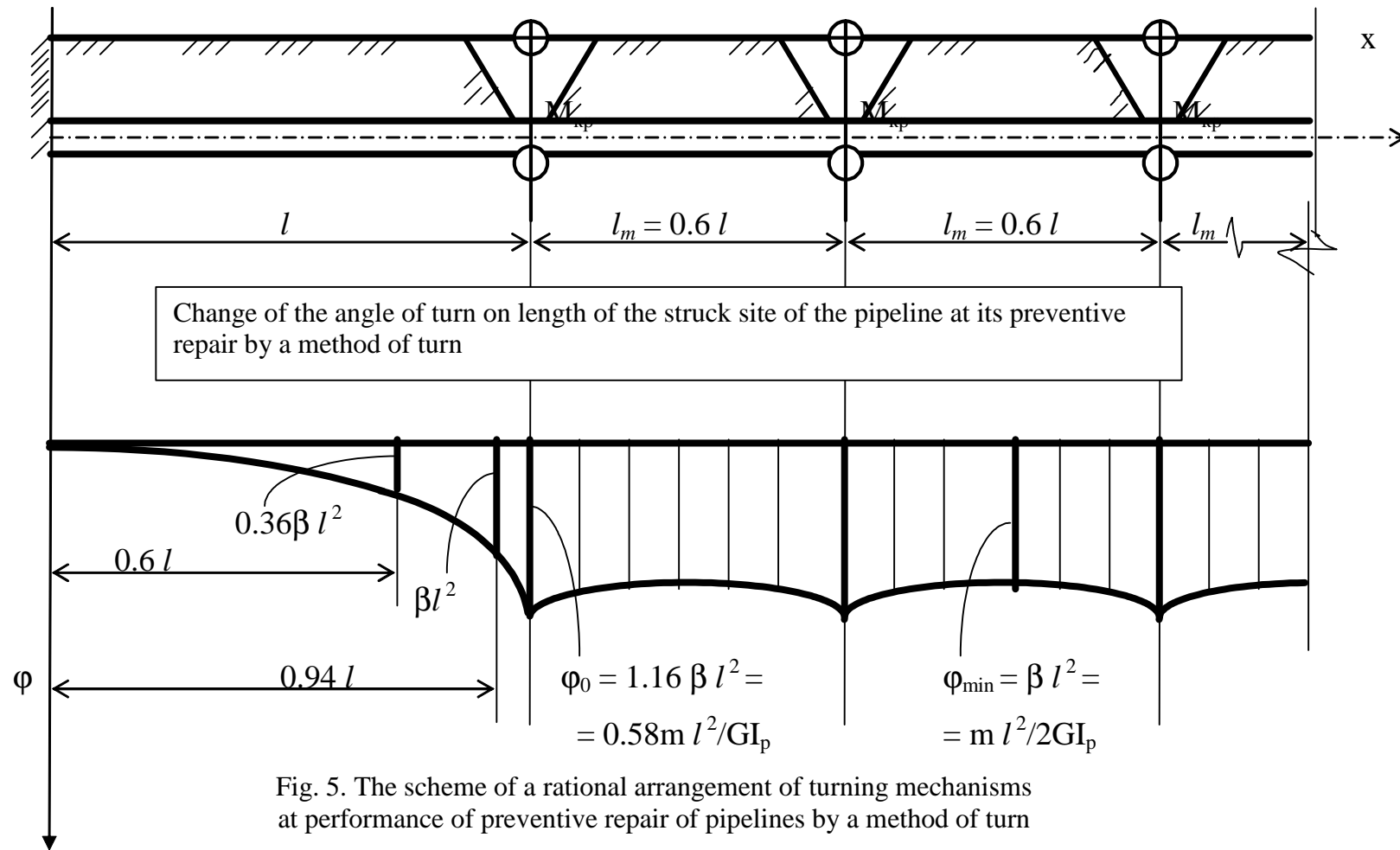

Fig. 5. The scheme of a rational arrangement of turning mechanisms at performance of preventive repair of pipelines by a method of turn

Let's copy as a quadratic:

$$x^2 - 0.6lx - 0.32l^2 = 0, \quad (11)$$

its decision gives $x=0.94l$.

From the analysis of the received results follows, that at performance of preventive repair by a method of turn, the first mounting is necessary for arranging the device in the beginning of the struck site of the pipeline.

Knowing characteristics of the pipeline and the sizes of a groove in cross section, appoint minimally necessary angle on which it is necessary to turn the pipeline [3].

Having increased this angle on 16 %, determine an initial angle of turn φ_1 (fig. 5) for the first section. Accepting distance between turning mechanisms $l_m = 0,6l$, carry out turn of the struck site of the pipeline consistently or in parallel, depending on its length.

The rational arrangement of turning devices has some advantages in comparison with application of the greatest distance between turning devices.

1. The minimal difference between the greatest and the least angles of turn of sections of the pipeline (only 16 %).
2. The opportunity of numerous performance of turn in process of formation of a new groove.
3. Decrease residual (after turn) is intense - deformed conditions.
4. Reduction of a return angle of turn.

References

1. Abdullin I.G. etc. The mechanism of destruction bottom forming on pipelines. - M.: Petroleum facilities journal, 1984.
2. Sultanmagomedov S.M., Bikov L.I. Substantiation of a way of preventive repair of the oil pipelines subject to corrosion. // Corrosion protection and preservation of the nature. - M.: USRIO&EPG, 1995.№ 4. - p. 10-12.
3. Sultanmagomedov S.M., Bikov L.I., Jusupov F.Sh. A way of preventive repair of the trade oil pipelines subjected to corrosion. // Corrosion protection and preservation of the nature. - M.: USRIO&EPG, 1994.№ 3. - p. 15-17.